

Malenki-Nano speed controller & receiver

Designed for 150g UK Antweight Robots

Radio protocol: AFHDS 2A

Compatible transmitters: Turnigy / Flysky FS i6, i4, Evolution etc

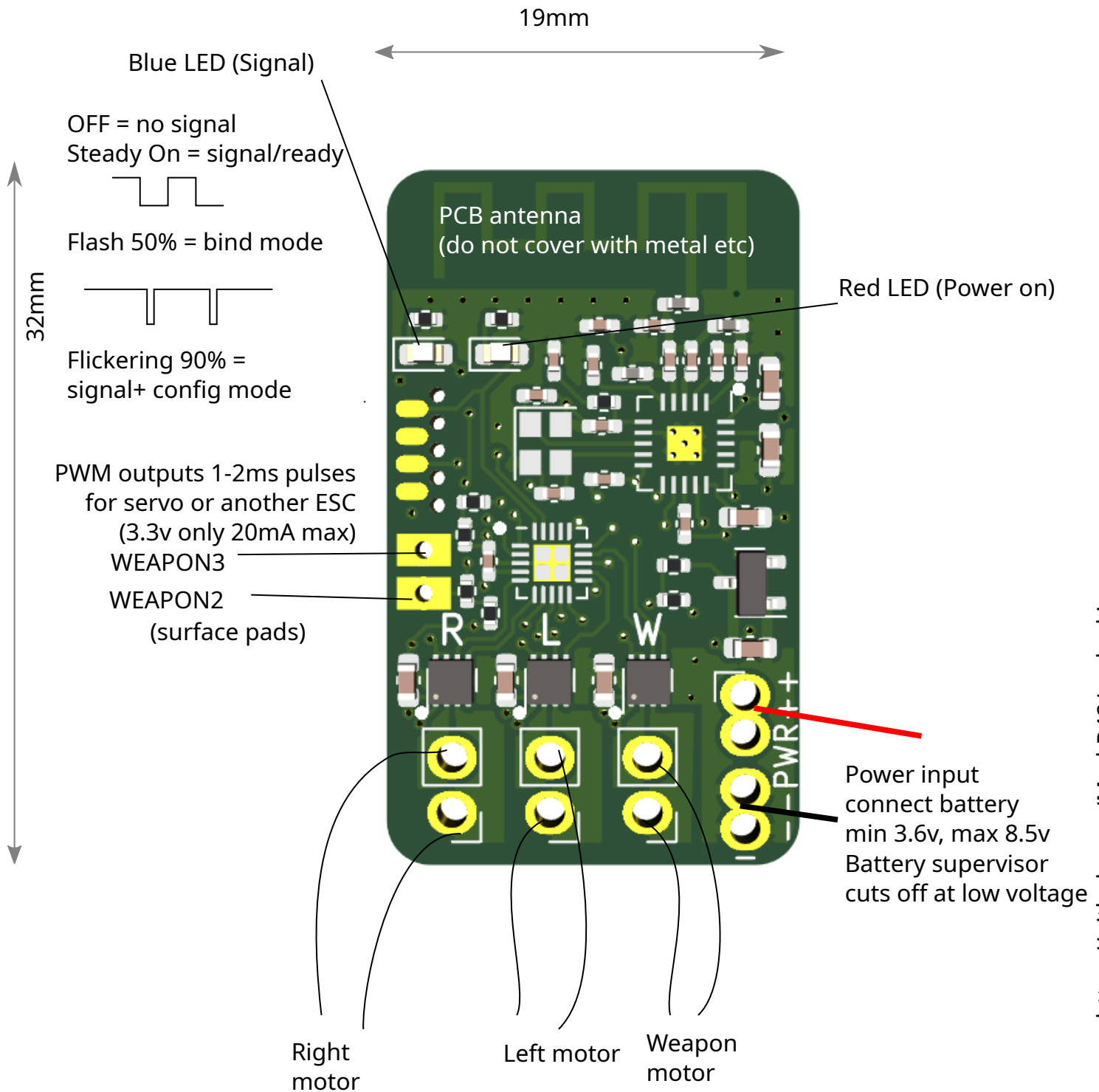

Brushed motor outputs: full battery voltage, 1.8A max current per channel

Channel mappings

- 1 = Steering
- 2 = Throttle
- 3 = WEAPON
- 4 = WEAPON2 (PWM)
- 5 = Invert / Configuration
- 6 = WEAPON3 (PWM)

Configuration commands

- Assign a switch to channel 5.
- Press a number of times while in config mode.
- 2 = Invert left output
- 3 = Invert right output
- 4 = Invert weapon output
- 5 = Reset control settings (keep bind)
- 6 = Enable / disable mixing (default enabled)
- 7 = Factory reset (unbind)